



The Chemical Company

PRODUCT DATA

7 07 14 00 Fluid-Applied Waterproofing

SONOSHIELD® HLM 5000®

Liquid, cold-applied elastomeric waterproofing membrane system

Description

HLM 5000® is a one-component, moisture-curing, bitumen-modified polyurethane elastomeric waterproofing membrane for exterior below-grade or between-slab applications. It is available in 4 grades for application by trowel, squeegee, roller and spray.

HLM 5000® comes in a variety of grades for different applications:

HLM 5000® SL (self-leveling) is formulated for application by squeegee to horizontal areas.

HLM 5000® T (trowel) is formulated for application by trowel to vertical surfaces.

HLM 5000® S (spray) is a specially formulated version of 5000T for spray application.

HLM 5000® R (roller) is formulated for application by roller to vertical and some horizontal surfaces.

Yield

25 – 30 ft²/gallon at 55 – 65 wet mils (0.61 – 0.74 m²/L at 1.4 – 1.7 mm wet thickness)

25 – 30 ft²/gallon at 45 – 55 dry mils (0.61 – 0.74 m²/L at 1.1 – 1.4 mm dry thickness)

Coverage may vary with the application technique used. Actual coverage rate and mil thickness depend on finish and porosity of the substrate.

Features

- Standard and high-build systems
- Waterproof
- Elastomeric
- Wide service-temperature range
- Chemical resistant
- Seamless cold-applied membrane
- Asphalt-modified polyurethane

Benefits

- Provides specification versatility and extended warranty
- Protects concrete structures from water penetration
- Permits expansion and contraction
- Suitable for all climates
- Resists bacterial attack and many acids, alkalis, and salts
- Eliminates lapping, seaming, and precutting
- Requires no hot-melt equipment

Packaging

HLM 5000® SL, HLM 5000® S, and HLM 5000® R: 5 gallon (18.95 L) pails

55 gallon (208 L) drums; available special order

HLM 5000® T: 5 gallon (18.95 L) pails

Sonosshield® Reinforcing Fabric: 300 ft by 37-1/2" (91 by 0.9 m) rolls, yielding 937 ft² (87 m²)

Protection Course II:

50 mil by 40" by 48" (1.3 mm by 1 m by 1.2 m) sheets, 500 per pallet, yielding 13-1/3 ft² (1.2 m²) per sheet or 6,665 ft² (619 m²) per pallet.

120 mil (1/8") by 40" by 48" (3 mm by 1 m by 1.2m) sheets, 500 per pallet, yielding 13-1/3 ft² (1.2 m²) per sheet or 6,665 ft² (619 m²) per pallet.

Color

Black

Shelf Life

6 months when properly stored

Storage

Store in unopened containers in clean, dry conditions at 40 to 80° F (4 to 27° C). During storage, an easily removed skin of HLM 5000® may form, which does not affect performance of the product.

Where to Use

APPLICATION

- Parking garages and concrete tanks
- Plaza decks and malls
- Fountains and pools
- Balconies and planters
- Bridges and highways
- Below-grade slabs
- Walls and culverts
- Sea walls, dams and reservoirs

LOCATION

- Exterior below grade (on masonry, concrete, and incidental metal)
- Above grade (between two-course concrete and within cavity walls)

SUBSTRATE

- Concrete
- Plywood (exterior)



Technical Data

Composition

HLM 5000® is a bitumen-modified polyurethane.

Compliances

- ASTM C 836
- National standard of Canada 37.58 - M86 developed by CGSB

Typical Properties

HLM 5000®

PROPERTY	VALUE
Minimum recovery, %	90
Swelling in water, 3 days at room temperature	Nil
Service temp. range, ° F (° C)	
Minimum	-40 (-40)
Maximum	120 (49)

SONOSHIELD® REINFORCING FABRIC

PROPERTY	VALUE
Width, in	
Minimum	37-1/2
Maximum	38-1/2
Length, ft	300
Thickness, in	(FTM-5136) 0.024 (-0.0, + 0.002)
Nominal weight, oz/yd²	2.13
Construction, in²	34 by 30
Yarn denier	70

Test Data

HLM 5000® (SELF-LEVELING GRADE)

PROPERTY	RESULTS		TEST METHODS
	High-Build System	Standard System	
Hardness, Shore 00	N/A	85	ASTM C 836
Viscosity, poise			Brookfield
HLM 5000® SL	125		
HLM 5000® S	450		
HLM 5000® R	800		
HLM 5000® T	4,000		
Tensile strength, psi (MPa)	200 (1.4)	150 (1.0)	ASTM D 412
Average elongation, %	300 ¹	600	ASTM D 412
100% modulus, psi (Mpa)	80 (0.6)	80 (0.6)	ASTM D 412
Moisture-vapor permeability, dry perms	0.075	0.1	ASTM E 96
Crack bridging test, cycled 10 times per 24 hours at 15° F (-9° C)	Passed 1/4"; no loss of bond or or cracking exhibited	Passed 1/16"; no loss of bond or cracking exhibited	ASTM C 836
Extensibility after heat aging		No cracking	ASTM C 836
Adhesion in peel, lbs/in (1 lb/in minimum)	5		ASTM C 836
Weight loss, % (20% max)		16	ASTM C 836

Results shown are typical but are not intended as performance criteria for on-site installed material.

¹Tested in direction of greatest elongation of fabric

SONOSHIELD® REINFORCING FABRIC

PROPERTY	RESULTS	TEST METHODS
Elongation, %		ASTM 5034
Machine direction	54	
Cross direction	147	
Grab breaking, lbs		ASTM 5034
Machine direction	54	
Cross direction	32	
Mullen burst, psi	70	

PROTECTION COURSE II

PROPERTY	RESULTS	TEST METHODS
Weight, lbs/ft²		
50 mil	0.188	
120 mil	0.428	
Burst strength, psi (MPa)	175	ASTM D 2529
Puncture resistance, in-lbs	45	ASTM D 781

Test results are averages obtained under laboratory conditions. Reasonable variations can be expected.

How to Apply HLM 5000®

Surface Preparation

1. For best results, all concrete deck surfaces should be lightly steel troweled to a flat, uniform surface. A light broom finish is acceptable. New concrete must be properly water cured at least 14 days. Membrane curing compounds must be mechanically removed.
2. For extremely porous block, a parge coat may be required, or prime with a coat of HLM 5000® diluted up to 25% with Sonneborn® Reducer 990. Apply Thoroseal at the rate of approximately 400 ft² (37.2 m²) per bag for the parge coat. Allow to cure a minimum of 7 days before applying HLM 5000®.
3. Remove dust, dirt and other contaminants just before or during application. Surfaces must be dry at the time of application.
4. Air-void pockmarks or honeycombs must be opened up to allow HLM 5000® to fill the cavities completely. Air entrapment within voids may cause blisters. Extreme cases may require a parge coat.

PRESTRIPING

1. Before applying the final membrane, all joints, cracks and openings around protrusions must be sealed by caulking or prestriping (a preliminary coating of HLM 5000® applied with a trowel or stiff-bristled brush). Allow to dry overnight before applying final membrane.
2. When the final membrane is applied, the overall thickness over joints and cracks, at coves and around penetrations should be approximately 100 wet mils (2.5 mm) on the standard system.

STATIC JOINTS AND CRACKS

Joints and cracks less than 1/16" (1.6 mm) should be filled by prestriping. Apply material so it both fills and overlaps the joint or crack to a width of 4" (102 mm) on each side.

WORKING OR EXPANSION JOINTS

All joints over 1/8" (3 mm) must be sealed with a Sonolastic® sealant. Any working joint less than 1/8" (3 mm) should be routed to a minimum of 1/8" (3 mm) and filled with a Sonolastic® sealant. Prevent the waterproofing membrane from adhering to the joint sealant, which could cause sealant or membrane failure, by applying a coat of wax or teflon tape over the cured sealant and then prestriping.

METAL

Clean all metal to bright metal by wire brush or sandblast. Prime with a quality rust-inhibiting metal primer and Sonneborn® Primer 733 or 766 (see Form No. 1017962) before application of HLM 5000®.

VENT, DRAIN PIPE, AND POST PENETRATIONS

1. Clean metal surfaces to bright metal and prime with a quality rust-inhibiting metal primer followed by Primer 733 or 766. Remove dust, debris and any other contaminants from voids. Seal with the appropriate Sonolastic® sealant.
2. Openings exceeding 1/8" (3 mm) must first be sealed with Sonolastic® sealant. Next, prestripe to a minimum width of 4" (102 mm) on the base slab and continue up the penetration to the height of the top-course wearing surface.

Application

A test application is always recommended before proceeding with entire application.

NOTE: Finish coat must be applied in a pinhole-free, continuous membrane for waterproofing integrity.

STANDARD SYSTEM

1. Select the grade of HLM 5000® that best meets individual job requirements. Use HLM 5000® T for trowel application, HLM 5000® S for spray application, HLM 5000® R for roller application or HLM 5000® SL for squeegee application.
2. For horizontal applications, empty contents of pail and spread immediately to ensure workability. Best results are obtained by marking off 125 ft² (11.61 m²) areas and evenly spreading the contents of a 5 gallon (18.93 L) unit with a rubber-edged notched squeegee. Repeat the above procedure until the entire surface is covered.
3. For vertical applications, apply by trowel, roller or spray at the rate of 25 ft²/gallon (0.6 m²/L). Best results are obtained by marking off 125 ft² (11.6 m²/L) and evenly applying the contents of a 5 gallon (18.93 L) pail.
4. Verify the applied thickness with a wet mil gauge as the work progresses.
5. The integrity of the cured membrane on a horizontal surface may be verified by damming the entire area and flooding with water to a minimum depth of 2" (51 mm) and allowing the water to stand for 24 – 48 hours. Visually inspect the bottom surface to check for any water penetration. If repairs are necessary, the area should be drained and allowed to dry before reapplying HLM 5000®. After reapplication, the area should be tested again for membrane integrity.

HIGH-BUILD SYSTEM

CONCRETE APPLICATION: Apply 60 wet mils of HLM 5000®, followed by setting Sonoshield® Reinforcing Fabric into the wet material. Overlap all seams a minimum of 3" (76 mm). Additional material may be required to properly embed the reinforcing fabric where it overlaps. Allow the first coat to cure overnight and follow with a second 60 wet-mil application of HLM 5000®.

PLYWOOD APPLICATION: All plywood construction must comply with APA (American Plywood Association) standards. Caulk all joints with a Sonolastic® sealant and then proceed with the HLM 5000® high-build system.

Spray Equipment

For spray equipment recommendations, consult the equipment manufacturer.

Curing

Appreciable properties develop within 24 – 48 hours at 75° F (24° C) and 50% relative humidity. Protect HLM 5000® from traffic during curing.

Drainage and Protection

1. For protection during backfill and where hydrostatic pressure is anticipated, use the appropriate Sonoshield® DBS Drain Board System. See Form No. 1017870 for installation instructions.
2. For protection during backfill only, install protection board as soon as possible following cure of HLM 5000®.

Clean Up

Clean all tools and equipment immediately after application with Sonneborn® Reducer 990.

How to Apply Protection Course II Surface Preparation

1. Waterproofing membranes must be protected against tear, puncture, and other abuses during placement of concrete wearing slabs and reinforcing steel. They should also be protected from jobsite traffic and backfilling operations.
2. All specifications calling for membrane waterproofing should also require protection of membrane as an integral part of the overall waterproofing system.

Application

1. Install tightly butted Sonneborn® Protection Course II as soon as possible following cure of the liquid membrane. Protect HLM 5000® from traffic before placement of protection board. HLM 5000® must be cured before installation of any topping.

2. Where hot bituminous topping is to be applied over the 1/4" (6 mm) thick protection board, cover the butt joints with flexible tape. Minimum topping thickness is 3" (76 mm), as recommended by the Asphalt Institute, in order to minimize crack reflection.

For Best Performance

HLM 5000®

- Apply HLM 5000® when substrates are dry and air temperatures are 40 to 90° F (4 to 32° C); for application at temperatures below 40° F (4° C), consult Technical Services.
- Cold temperatures influence viscosity and handling characteristics of HLM 5000®: heat increases and cold decreases the flow. Keep HLM 5000® cool in hot weather and warm in cold weather.
- Avoid application when inclement weather is present or imminent.
- Do not apply to reinforcing bars or to wet or contaminated surfaces.
- Do not directly heat containers with flame, stove, hot plate or oven.
- Patch all voids and deep depressions in substrates with appropriate patching material before applying HLM 5000®.
- Use Sonneborn® Flextight™ (see Form No. 1017953) under thin-set tile applications.
- Before applying HLM 5000®, dam all drains and drain openings.
- Carefully work material over irregular concrete to avoid pinholes and holidays.
- Protect HLM 5000® coated surfaces from puncture with protection board until required topping or backfill is placed.
- Not intended as an exposed or wearing surface.
- Do not use where a solvent odor is objectionable, e.g., near areas where food preparation or processing take place during the application.
- Specify wet or paper curing for concrete to be coated with HLM 5000®; avoid using liquid curing compounds.
- Apply asphalt overlay in accordance with asphalt industry and manufacturer's standards. The HLM 5000® membrane must be protected from heat, impact and any other damage that could be caused by an asphalt overlay.

PROTECTION COURSE II

- Store Protection Course II on a flat surface and keep it dry; do not remove shrinkwrap until immediately before use.
- Do not use 50 or 120 mil (1.3 or 3.0 mm) protection board in conjunction with bituminous overlays.
- If board is exposed to prolonged periods of water immersion or excessive humidity, it may curl or wrinkle.
- Protection Course II to be covered with a concrete wearing course must be securely attached to membrane.

GENERAL

- Make certain the most current versions of product data sheet and MSDS are being used; call Customer Service (1-800-433-9517) to verify the most current versions.
- Proper application is the responsibility of the user. Field visits by BASF personnel are for the purpose of making technical recommendations only and not for supervising or providing quality control on the jobsite.

Health and Safety

HLM 5000®

Warning

HLM 5000® contains Stoddard solvent, naphtha light aromatic, toluene diisocyanate, 1, 2, 4 trimethyl benzene, asphalt, hydrotreated heavy naphthenic petroleum distillates.

Risks

Combustible liquid and vapor. May cause skin, eye and respiratory irritation. May cause dermatitis and allergic responses. Potential skin and/or respiratory sensitizer. Ingestion may cause irritation of mouth, throat and stomach with nausea and abdominal pain. Reports associate repeated or prolonged occupational overexposure to solvents with permanent brain, nervous system, liver and kidney damage.
INTENTIONAL MISUSE BY DELIBERATELY INHALING THE CONTENTS MAY BE HARMFUL OR FATAL.

Precautions

KEEP AWAY FROM HEAT, FLAME AND SOURCES OF IGNITION. KEEP OUT OF THE REACH OF CHILDREN. Keep container closed. Use only with adequate ventilation. Avoid contact with skin, eyes and clothing. Wash thoroughly after handling. Avoid breathing vapors. Use impervious gloves, eye protection and if the TLV is exceeded or if used in a poorly ventilated area, use NIOSH/MSHA approved respiratory protection in accordance with applicable federal, state and local regulations. Empty container may contain explosive vapors or hazardous residues. Do not cut or weld on or near empty container. All label warnings must be observed until container is commercially cleaned or reconditioned.

First Aid

In case of eye contact, flush thoroughly with water for at least 15 minutes. SEEK IMMEDIATE MEDICAL ATTENTION. In case of skin contact, wash affected areas with soap and water. If irritation persists, SEEK MEDICAL ATTENTION. Remove and wash contaminated clothing. If inhalation causes physical discomfort, remove to fresh air. If discomfort persists or any breathing difficulty occurs, or if swallowed, SEEK IMMEDIATE MEDICAL ATTENTION.

Refer to Material Safety Data Sheet (MSDS) for further information.

Proposition 65

This product contains materials listed by the state of California as known to cause cancer, birth defects or other reproductive harm.

VOC Content

HLM 5000® SL: 1.53 lbs/gal or 183 g/L.

HLM 5000® S: 1.58 lbs/gal or 190 g/L.

HLM 5000® R: 1.5 lbs/gal or 180 g/L.

HLM 5000® T: 1.1 lbs/gal or 132 g/L.

**For medical emergencies only,
call ChemTrec (1-800-424-9300).**

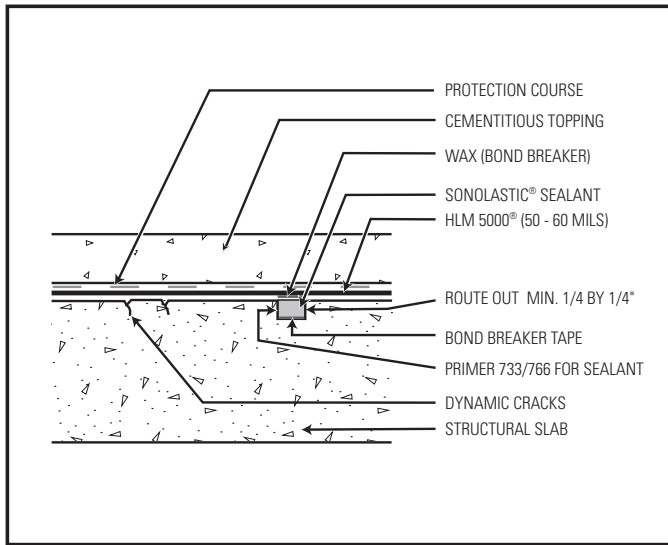

Dynamic Crack Detail

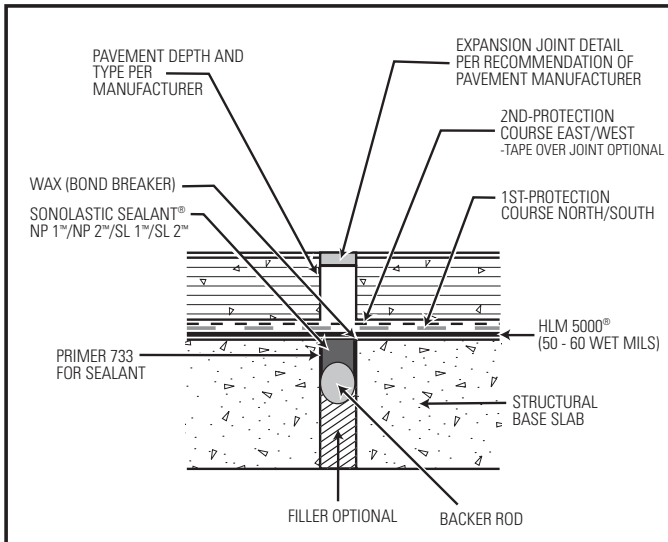

Asphalt Pavement Topping/Expansion Joint

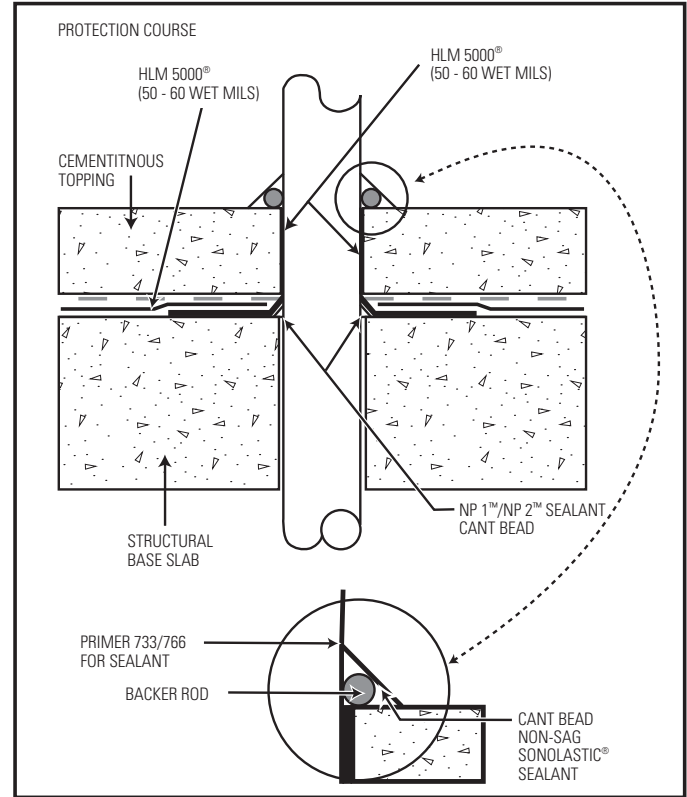

Vent/Drain/Pipe/Post Penetration Detail

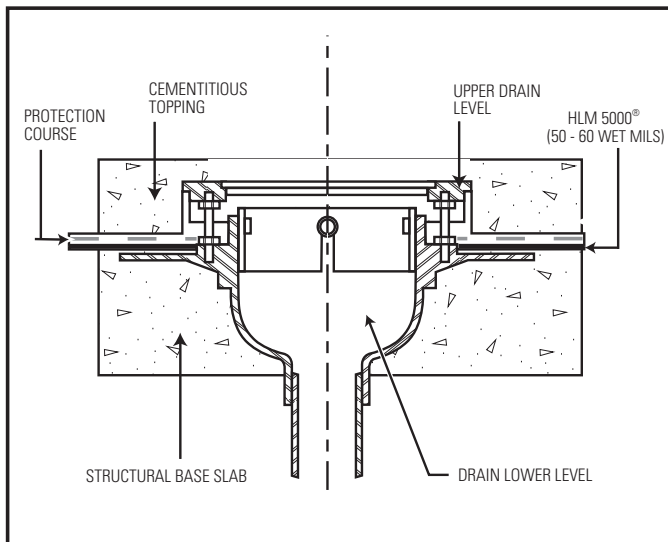

Waterproofing at Bi-Level Drain

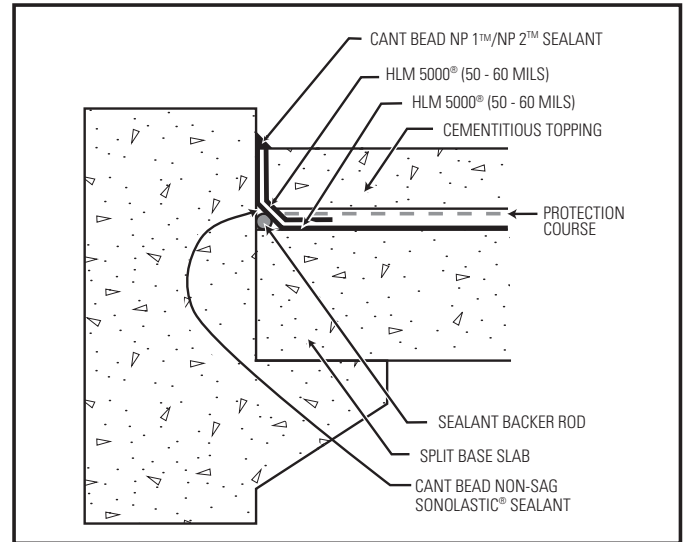

Split Slab with Cant Detail

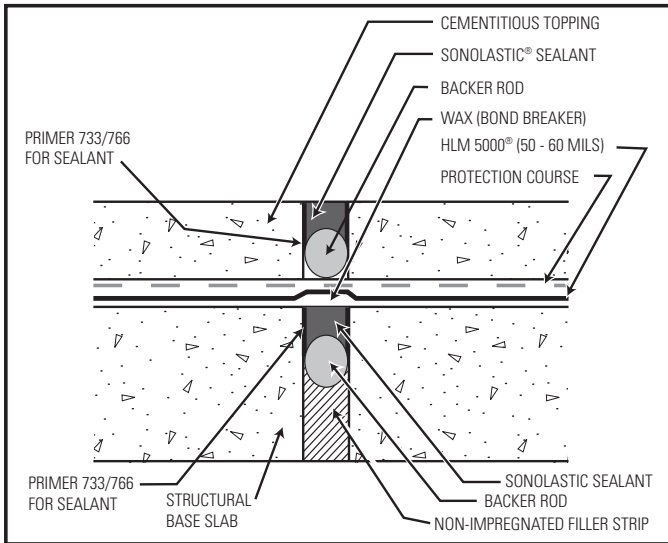

Expansion Joint Detail

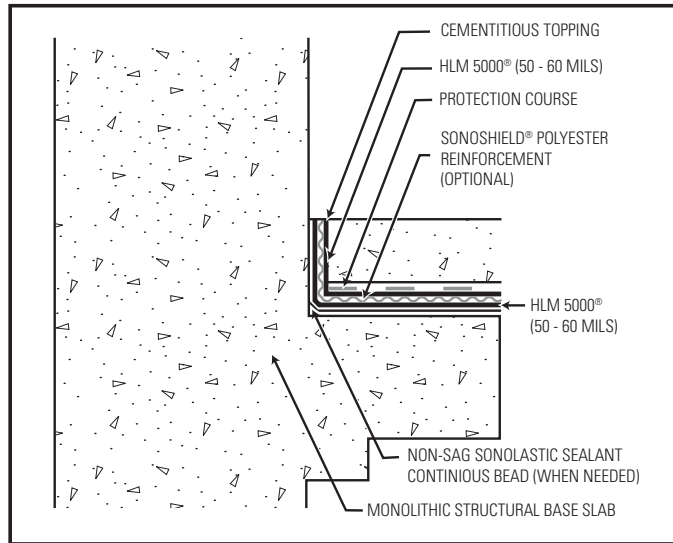

Inside Corner Detail (Static)

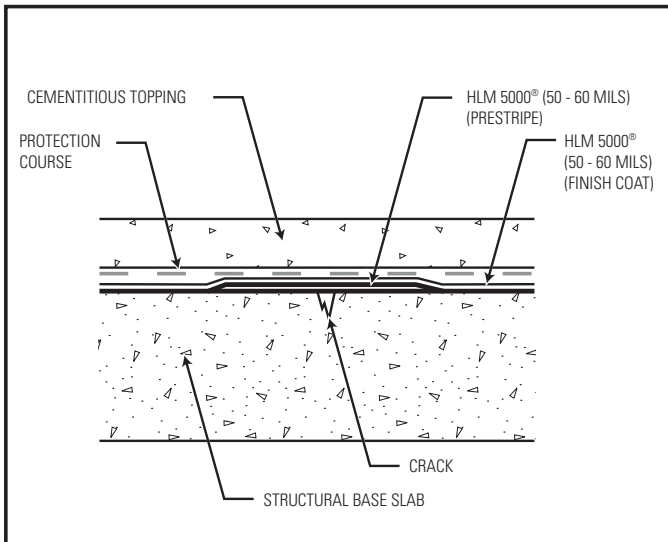

Static Crack/Prestripe Detail

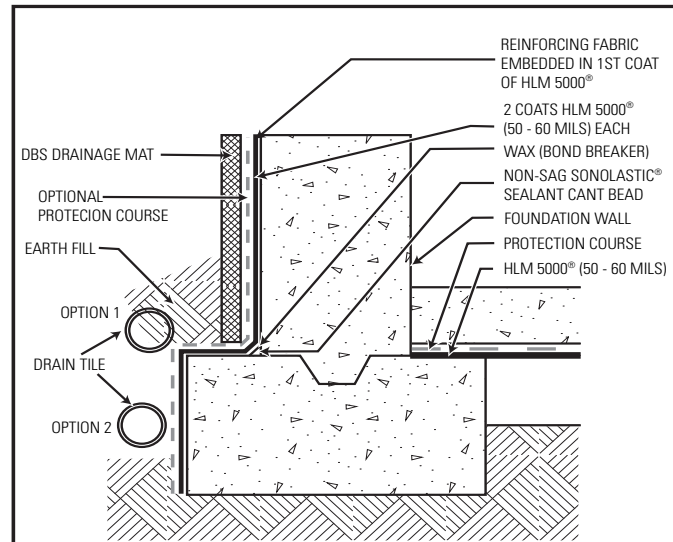

Waterproofing Foundation Walls

**BASF Corporation
 Building Systems**

889 Valley Park Drive
 Shakopee, MN, 55379

www.BuildingSystems.BASF.com

Customer Service 800-433-9517

Technical Service 800-243-6739

16.6



LIMITED WARRANTY NOTICE Every reasonable effort is made to apply BASF exacting standards both in the manufacture of our products and in the information which we issue concerning these products and their use. We warrant our products to be of good quality and will replace or, at our election, refund the purchase price of any products proved defective. Satisfactory results depend not only upon quality products, but also upon many factors beyond our control. Therefore, except for such replacement or refund, BASF MAKES NO WARRANTY OR GUARANTEE, EXPRESS OR IMPLIED, INCLUDING WARRANTIES OF FITNESS FOR A PARTICULAR PURPOSE OR MERCHANTABILITY, RESPECTING ITS PRODUCTS, and BASF shall have no other liability with respect thereto. Any claim regarding product defect must be received in writing within one (1) year from the date of shipment. No claim will be considered without such written notice or after the specified time interval. User shall determine the suitability of the products for the intended use and assume all risks and liability in connection therewith. Any authorized change in the printed recommendations concerning the use of our products must bear the signature of the BASF Technical Manager.

This information and all further technical advice are based on BASF's present knowledge and experience. However, BASF assumes no liability for providing such information and advice including the extent to which such information and advice may relate to existing third party intellectual property rights, especially patent rights. In particular, BASF disclaims all CONDITIONS AND WARRANTIES, WHETHER EXPRESS OR IMPLIED, INCLUDING THE IMPLIED WARRANTIES OF FITNESS FOR A PARTICULAR PURPOSE OR MERCHANTABILITY. BASF SHALL NOT BE RESPONSIBLE FOR CONSEQUENTIAL, INDIRECT OR INCIDENTAL DAMAGES (INCLUDING LOSS OF PROFITS) OF ANY KIND. BASF reserves the right to make any changes according to technological progress or further developments. It is the customer's responsibility and obligation to carefully inspect and test any incoming goods. Performance of the product(s) described herein should be verified by testing and carried out only by qualified experts. It is the sole responsibility of the customer to carry out and arrange for any such testing. Reference to trade names used by other companies is neither a recommendation, nor an endorsement of any product and does not imply that similar products could not be used.

For professional use only. Not for sale to or use by the general public.

Form No. 1017900 10/11
 Printed on recycled paper including 10% post-consumer fiber.

© 2011 BASF
 Printed in U.S.A.